

TVS 

OWNER'S MANUAL

BS-VI



www.tvsx.com

TVS
XL100
It's my time now



ALWAYS USE TVS-M GENUINE PARTS

CONTACT(S) FOR SUPPORT	1
FOREWORD	5
NOTICE	6
SAFETY INFORMATION	7
RUNNING-IN INFORMATION	8
KNOW YOUR TVS XL100	9
RIDING YOUR TVS XL100	22
MAINTENANCE	26
EXPRESS SERVICE	48
EXPERT ON WHEELS	49
PICKUP AND DROP	50
WARRANTY AND SERVICES	51
SERVICE INFORMATION	55
TECHNICAL SPECIFICATIONS	58
GENERAL INFORMATION	63



Incase you need any clarification please contact

TVS Motor Company Authorised Main Dealer / Authorised Dealer

Or

TVS Motor Company's Area Offices (flip over for addresses)

Or

Toll Free Number : 1800-258-7111

Email : customercare@tvsmotor.com

Disclaimer : TVS Motor Company or any of its officials / Authorized Main dealer / Authorized Dealer do not ask customers for bank / card / wallet details / authentication. In case you face any such claim, please report to the relevant local authorities immediately.

CONTACT AT OUR AREA OFFICES**TAMILNADU-1, 3 & 4****1. TVS Motor Company Limited**

V Floor, Gee Gee Universal,
No. 2, MC Nichols Road,
Chetpet, Chennai - 600 031.
Phone : 044-28361651/28361654
Email : AO.Chennai@tvs motor.com
AO.Madurai@tvs motor.com

TAMILNADU-2**2. TVS Motor Company Limited**

No. 10, 2nd floor,
Shree Shanmugapriya Towers,
Kannuswamy Street,
Behind Hotel Annapoorna,
R S Puram, Coimbatore - 641 002.
Phone : 0422-4350060/2541035
Email : AO.Coimbatore@tvs motor.com

KERALA**3. TVS Motor Company Limited**

Ambady Towers, Second Floor,
Door No. 27/631, A6,
Edappally-Pookkattupady Road,
Edappally PO., Cochin - 682 024.
Phone : 0484-2544578/2556938
Email : AO.Cochin@tvs motor.com

KARNATAKA-1, 2 & GOA**4. TVS Motor Company Limited**

No. 600, Anand Surya, 2nd Floor,
15th Cross, 6th Phase, JP Nagar,
Opp. BMTC Bus Stop,
Bangalore - 560 078.
Phone : 080-26653433
Email : AO.Bangalore@tvs motor.com
AO.Hubli@tvs motor.com

ANDHRAPRADESH -1 & 2**5. TVS Motor Company Limited**

Rukumani Towers, First Floor,
No. 3-11-30, Plot No. 11,
Paigha Colony, Behind Anand Theater,
Secunderabad - 500 003.
Phone : 040-27840590/27844419
Email : AO.Hyderabad@tvs motor.com
AO.Vijayawada@tvs motor.com

MAHARASHTRA-1 & 2**6. TVS Motor Company Limited**

No. 401, 4th Floor, The Chambers,
Plot No. 4/12/3, Near Ganapati Chowk,
Viman Nagar, Pune - 411 014.
Phone : 020-26632111/26632110
Email : Service.pune@tvs motor.com

MAHARASHTRA-3 & CHATTISGARH**7. TVS Motor Company Limited**

No. 502B, 6th Floor, B Wing,
Shriram Shyam Towers,
Near LIC Square, Sardar,
Nagpur - 440 001.
Phone : 0712-2569932
Email : Service.Nagpur@tvs motor.com
AO.Rajpur@tvs motor.com

GUJARATH**8. TVS Motor Company Limited**

109, Ayna Complex,
Opp. Suvarna Villa Bungalows,
100 ft Thaltej Hebbatpur Road,
Off : S.G. Highway, Thaltej,
Ahmedabad - 380 054.
Phone : 079-65443748
Email : AO.Ahmedabad@tvs motor.com

MADHYA PRADESH-1 & 2**9. TVS Motor Company Limited**

No. 211-212, 2nd Floor,
Chinar Incube Business Centre,
Chinar Fortune City,
Near Brindhavan Dhaba,
Hosangabad Road,
Bhopal - 462 026.
Phone : 0755-2499406/2499306
Email : AO.Bhopal@tvs motor.com
AO.Indore@tvs motor.com

RAJASTHAN-1 & 2**10. TVS Motor Company Limited**

Plot No. 17-18,
2nd Floor of National Motors Building,
Jhotwara Industrial Area,
Jaipur - 302 012.
Phone : 0141-5150901/5150902
Email : AO.Jaipur@tvs motor.com
AO.Udaipur@tvs motor.com

DELHI & HARYANA**11. TVS Motor Company Limited**

D-3 & D-4, 2nd Floor,
Sector - 10, Noida,
Uttar Pradesh - 201 301.
Phone : 011-29834640/29834773
Email : AO.Delhi@tvs motor.com
AO.Haryana@tvs motor.com

PUNJAB & CHANDIGARH**12. TVS Motor Company Limited**

4th Floor, Royal Business Park,
Chandigarh Ambala Highway,
Zirkapur - 140 603.
Phone : 01762-464777/465777
Email : AO.Chandigarh@tvs motor.com

UTTAR PRADESH WEST**13. TVS Motor Company Limited**

D-3 & D-4, 2nd Floor,
Sector - 10, Noida,
Uttar Pradesh - 201 301.
Phone : 011-29834640/29834773
Email : AO.Upw@tvs motor.com

UTTAR PRADESH CENTRAL & EAST**14. TVS Motor Company Limited**

1st Floor, Cyber Tower, TC-34/V-2,
Vibhuti Khand, Gomti Nagar,
Lucknow - 226 010.
Phone : 0522-4918300/4918301
Email : AO.Upe@tvs motor.com
AO.Upc@tvs motor.com

WEST BENGAL**15. TVS Motor Company Limited**

Ground Floor & First Floor,
133 A. S. P. Mukherjee Road,
Opp. Tollygunge Police Station,
Kolkatta - 700 026.
Phone : 033-24617096/24617092
Email : AO.Kolkatta@tvs motor.com

BIHAR**16. TVS Motor Company Limited**

N-Plaza, Jamal Road,
P.S. Kotwali,
Patna - 800 001.
Phone : 0612-2200068/2200069
Email : AO.BNJ@tvs motor.com

ORISSA & JHARKHAND

17. TVS Motor Company Limited

No. 303, 3rd Floor,
Creative Plaza, Rasulgarh,
Bhubaneswar - 751 010.
Phone : 0674-2580019
Email : AO.Bhubaneswar@tvsmotor.
com

NORTH EAST STATES

18. TVS Motor Company Limited

147, Udayan, Ganesh Guri,
Opp. Punjab National Bank,
R G B. Road, Guwahati - 781 005.
Phone : 0361-2202030/2202031
Email : AO.Guwahati@tvsmotor.com

Dear Customer,

Congratulations! Over one crore Indians are part of the TVS XL family and now, it gives us great pleasure to welcome you to it. We hope you have a great journey ahead just as millions of satisfied TVS customers have.

With stringent quality checks, great attention and care has been taken to ensure that your TVS XL100 is in a perfect operating condition as it leaves our factory. With a powerful engine and great new features, all you have to do is to fill up your new TVS XL100 with fuel and get going.

This manual will help you get the best performance out of your new TVS XL100. From information on how best to ride it to its maintenance, you will find all the relevant information in the following pages. Follow them carefully to make the most of your vehicle.

We're delighted to inform you that as part of our company policy, you are entitled to benefits for the maintenance of your vehicle. Free services and other warranty repairs can be availed from the TVS Motor Company Authorised Main Dealers / Authorised Dealers nearest to you. The staff at the Authorised Main Dealers / Authorised Dealers have been trained by us to take great care of your after sales/service requirements.

We wish you a long and fruitful journey ahead with your TVS XL100, for years and years to come.

Warm regards,

TVS MOTOR COMPANY LIMITED

This manual should be considered as a permanent part of the vehicle and should remain with the vehicle when resold or transferred to a new owner.

All information, illustrations, photographs and specifications contained in this owner's manual are based on the latest product information available at the time of this publication. TVS Motor Company Limited may, however, incorporate modifications or improvements on its vehicles at any time without notice, and therefore, in such events it is possible that the relevant part of the owner's manual does not apply to your vehicle.

Prior permission of TVS Motor Company Limited is required for quoting, copying or reproducing any part of this owner's manual.

i **Note**

Accessories shown in the picture may not be a part of standard equipment.

Pictures shown in the manual are of TVS XL100 i-Touch Start until otherwise specified.

Since your vehicle is fitted with side stand cut-off system ensure to retract the side stand before starting the vehicle.

TVS XL100 comes with the BSVI compliant futuristic fuel injection technology which delivers best-in-class performance. Ensure to maintain the vehicle in its top-notch condition by getting it serviced periodically at TVS Motor Company Authorised Main Dealer / Authorised Dealer. Always drive the vehicle with enough amount of fuel (Low Fuel indicator shall not come ON).

Operating this vehicle safely is an important responsibility of the rider. To help you make decisions on safety, we have provided necessary operating procedure and other information in this manual. This information alerts you on potential hazards that could hurt you or others. Since it is not possible to warn you about all the hazards associated with operating or maintaining the vehicle, you must use your own judgement.

You will find important safety information in following form in this manual. These words carry the following connotations:

Warning

*Disregarding this message might result in **injury to the rider or deadly accidents.***

Caution

*This message indicates special procedures or precautions to be followed to **avoid damage to the vehicle.***

Note

*This message provides further clarification for **clear understanding of any particular information.***

The first 1000 km is a crucial part of your vehicle. Proper running-in operation during this period helps in ensuring a **maximum life** and **smooth performance** of your vehicle.

The reliability and performance of your vehicle depends on the special care and restraint exercised during the running-in period. It is especially important that you avoid operating the engine in high speed (RPM), which could expose the engine parts to excessive stress. Maximum recommended speed during the running-in is:

Maximum 40 kmph speed upto 1000 km (vary the engine speed for better mating of parts).

The first free service at 500 ~ 750 km is most important. During running-in period all the engine components and other parts will have set in. All adjustments to be restored, all fasteners to be tightened. Engine cum transmission oil to be replaced. Timely performance of the first free service will ensure optimum service life and performance from the engine.



Caution

Replacing the engine cum transmission oil during first free service is most important for better life of engine. Always use TVS TRU4 PREMIUM oil (SAE 10W30 API-SL, JASO MA2) for better performance and life.

*Since your vehicle is fitted with the Evaporative Emission Control System, **the vehicle should not be laid on the floor during water wash.** Else it may lead to difficulty in starting and improper running of the motorcycle.*



VEHICLE IDENTIFICATION NUMBER

The frame and engine serial numbers are the only means of identifying your vehicle from others of the same model and type. They are also required to assist your Dealer for ordering parts or referring to special information.

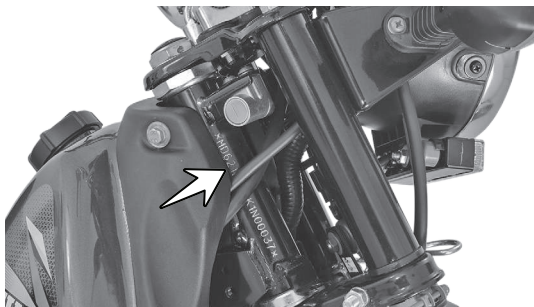

The frame serial number is stamped on the right side of the steering head tube.

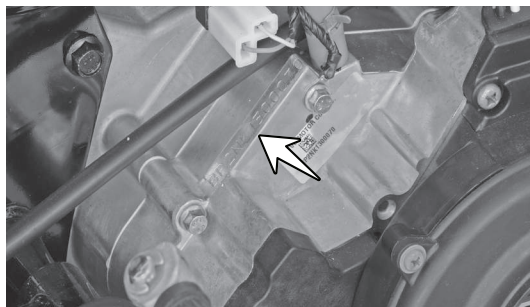

The engine serial number is stamped on the top surface of right side crankcase near engine breather tube.

LOCATION OF PARTS - HANDLE BAR

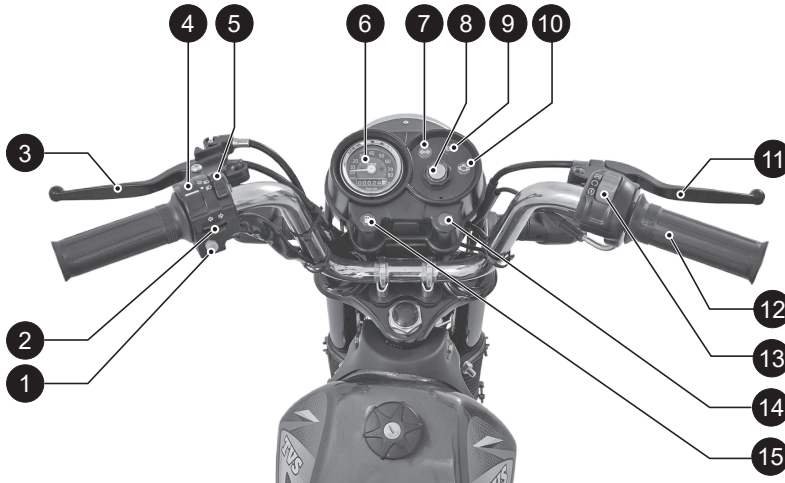

1. Horn switch
2. Turn signal lamp switch
3. Left hand brake lever
4. Head lamp switch
5. High / low beam switch
6. Speedometer
7. Turn signal indicator lamp
8. Ignition switch
9. High beam indicator lamp
10. Malfunction indicator lamp
11. Right hand brake lever
12. Throttle grip
13. i-Touch Start with Engine Kill switch**
14. Electric system indicator lamp**
15. Low fuel warning indicator lamp

** Applicable for 'i-Touch Start' models only

CONTROL KEY

TVS XL100 comes with a pair of identical control keys. These keys are to operate ignition lock, steering lock, fuel tank cap, tool box lock and seat lock*.

IGNITION LOCK

The ignition lock enables and disables the electrical circuit. The two positions of the lock are described below:

1. 'OFF' position

All the electrical circuits are deactivated. The key can be removed from the lock.

2. 'ON' position

All the electrical circuits are activated. Engine can be started. Control key cannot be taken out from the lock.

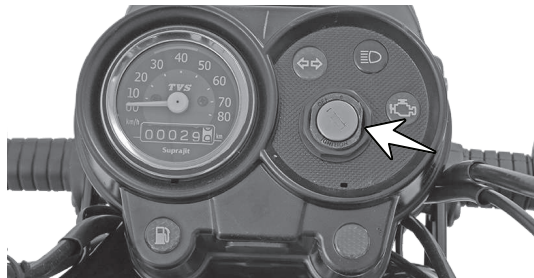

Warning

Keep the ignition key in OFF position, when the vehicle is not in use to prevent battery drain.**

If the vehicle is not started for prolonged time after switching ON the ignition key the vehicle may not start with the self start immediately. Turn OFF the ignition key and turn it ON again to start the vehicle using self start.**

Note

When you switch ON the ignition key, the pump priming noise may be heard which is normal. Avoid frequent switch OFF & ON of the ignition key to avoid unnecessary run of fuel pump.

Tail lamp, day time running lamp (DRL), brake lamp and head lamp of the vehicle glows only after starting the vehicle.

* Seat lock is not applicable for Comfort models

** Applicable for 'i-Touch Start' models only

SPEEDOMETER ASSEMBLY

1. Low fuel warning indicator lamp*

'Low Fuel Warning Indicator lamp (LFI)' is a safety indicator to caution you to fill the petrol as soon as possible. Minimum 1.25 liter of petrol will be available in the tank when this indication comes 'ON'.

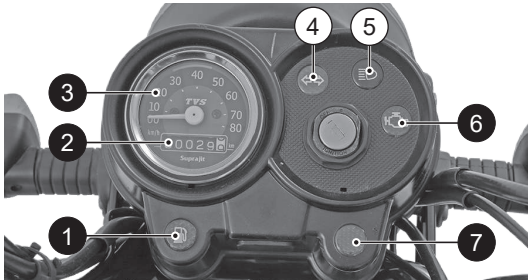

Caution

When the low fuel warning indicator lamp glows fill fuel immediately to avoid engine switch OFF / Damage to fuel pump which leads to replacement of pump without warranty.

* 'LFI' is not a mileage calculating medium and it should not be used for measurement of fuel consumption.

2. Odometer

Displays the total distance covered by the vehicle in kilometers. The last digit denotes one tenth of a kilometer.

3. Speedometer

Indicates vehicle speed in kilometers per hour.

4. Turn signal indicator lamp

Flashes when the 'left' or 'right' side turn signal lamp is activated.

5. High beam indicator lamp

Glow when the head lamp high beam is activated.

6. Malfunction indicator lamp (MIL)

MIL is turned ON when the ECU detects a fault in the system.

If the malfunction indicator lamp '  ' is glowing continually when the engine is started, immediately contact the nearest TVS Motor Company Authorised Main Dealer or Authorised Dealer.

Note

During every key ON, the MIL glows and turns OFF once the engine starts. This is a part of self check, which is normal.

7. Electrical system indicator lamp**

Electrical system indicator lamp (ESIL) blinks while starting the vehicle using electric starter and goes OFF once the engine gets started.

If this indicator glows continuously even after starting the vehicle, it indicates that there is some problem with the vehicle's electrical system. Contact TVS Motor Company Authorised Main Dealer / Authorised Dealer immediately.

i Note

If the ESIL lamp glows continuously once the ignition is turned ON, then there may be a issue with the vehicle's electrical system and the vehicle may not get started. Contact TVS Motor Company Authorised Main Dealer / Authorised Dealer incase if this error occurs.

Please make a note that the failure of bulbs will not be shown by the electrical system indicator lamp (ESIL) and MIL lamp.

DAY TIME RUNNING LAMP (DRL)

TVS XL100 comes with a day time running LED lamp which glows automatically once the engine is started and continue to glow till the engine is turned 'OFF' or head lamp is switched 'ON'.

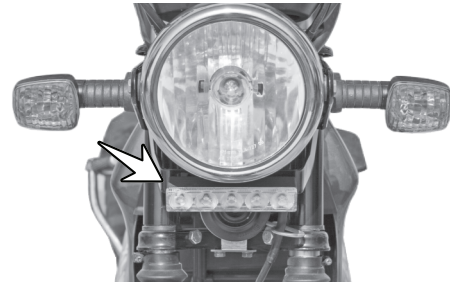

** Applicable for 'i-Touch Start' models only

HANDLE BAR LEFT SIDE

1. Horn switch

Press the switch '📢' to operate the horn.

2. Turn signal lamp switch

Slide the turn signal lamp switch to left '↶' or right side '↷' to operate respective turn signal lamps (LH/RH). Slide the knob to the center position to turn 'OFF' the lamps.

3. Left hand brake lever (SBT brake lever)

Synchronized Braking Technology (SBT) can be operated by pressing the left hand brake lever gently towards the handle grip.

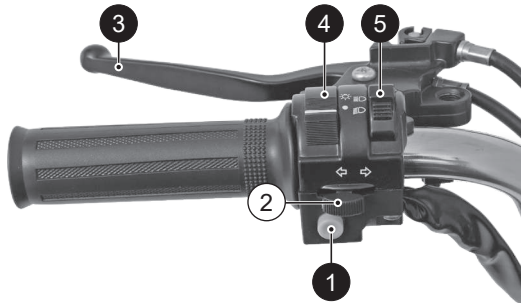

SBT technology helps to operate both front and rear brakes by distributing the force optimally between the two braking system. The brake lamp glows on application of brake.

Warning

In the vehicles fitted with SBT brake system, it is essential to maintain the brake system in good condition to ensure its effectiveness. Adjust the SBT at periodic intervals without fail for the proper working of system.

Always use the appropriate turn signal lamps when you intend to change lanes or take turns. Be sure to switch 'OFF' the turn signal lamps after negotiating the turns or lanes.

4. Head lamp switch

Head lamp switch has two positions, they are:

OFF : Head lamp and speedometer back illumination are turned 'OFF' when the switch is positioned at '●' even though the engine is running.

ON : Head lamp and speedometer back illumination glows when the switch is positioned at '☀️' and engine is running.

5. Head lamp high / low beam switch

With the head lamp in 'ON' condition, slide the beam control switch towards '☰D' to turn-on the head lamp high beam. Slide the switch towards '☷D' to turn-on the head lamp low beam.

Warning

Use appropriate head lamp beam 'high / low' as per the traffic and road conditions for your safety and to avoid inconvenience to other riders.

Note

In 'i-Touch Start' models, if the vehicle is left in idling for more than 20 seconds (approx.) with the head lamp ON condition, the intensity of the head lamp will reduce automatically to avoid draining of battery.

HANDLE BAR RIGHT SIDE

1. Throttle grip

Engine speed is controlled by the rotation of the throttle grip. Twist it towards you to increase the engine speed and away from you or release it to decrease the engine speed.

2. Right hand brake lever

The front brake is applied by squeezing the right hand brake lever gently towards the throttle grip. The brake lamp glows on application brake.



Warning

Brakes are items of personal safety and should always be maintained in proper condition.

3. i-Touch Start with Engine Kill switch**

TVS XL100 is provided with integrated i-Touch Start with Engine Kill switch.

The engine kill switch is used to switch off '⊗' the engine but to keep other DC system active. The ignition circuit is disabled, preventing the engine from being started. To restart the engine, return the switch to the '⊙' position.

To start the engine electrically, ensure the side stand is retracted, keep the switch in '⊙' position, apply any one the brake and press the switch to '⊗' position and release.

The ESIL lamp blinks while starting the vehicle electrically. Refer page No. 013 for more details.



Caution

*The vehicle cannot be started using electric starter with low / discharged battery or retracted side stand. In case of low / discharged battery, contact TVS Motor Company Authorised Main Dealer / Authorised Dealer for rectification. ***

** Applicable for 'i-Touch Start' models only

STEERING LOCK

TVS XL100 is provided with separate lock for locking the steering.

To lock the steering, turn the handle bar all the way to the left, insert the control key into the lock and rotate it in clockwise direction and take out. For unlocking insert the key in the lock and turn it in anti-clockwise direction and take out.

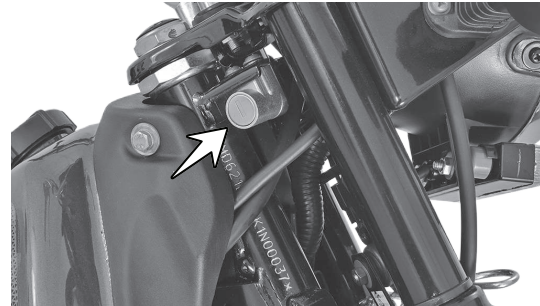

Warning

Never attempt to move the vehicle when the steering is locked, you may lose balance.

FUEL TANK* CAP

To open the fuel tank cap, insert the key into the lock and turn it in clockwise direction. Now, rotate the fuel tank cap in anti-clockwise direction and take out. Key cannot be taken out of the cap in this condition.

Fill the required amount of petrol (as per the tank capacity) and refit the fuel tank cap in the reverse order of removal.

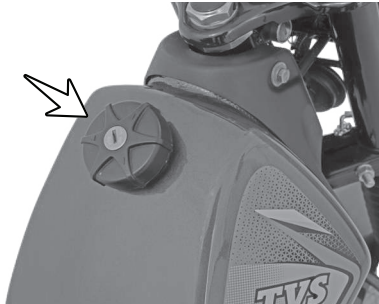

* Fuel tank is not a measuring instrument and capacity of the fuel tank may slightly vary from the indicated capacity.

Warning

Avoid spilling of fuel on the hot engine. Never refill fuel near open flame. Do not smoke while refueling. Do not use cell phones while refueling.

Note

Whenever refueling the vehicle, fill maximum upto the bottom of the neck portion of the fuel tank. Filling above the neck may result in seepage of fuel from the fuel tank cap.

EVAPORATIVE EMISSION CONTROL SYSTEM

This vehicle is fitted with Evaporative Emission Control System (EVAP). If there is any abnormal jerk, startability issue are felt in the vehicle or noise due to sudden escape of gas during opening of fuel tank cap, immediately report to the TVS Motor Company Authorised Main Dealer / Authorised Dealer.

Caution

Do not clean the vehicle by laying down on floor, to avoid fuel entry into EVAP system.

KICKSTARTER LEVER

The kickstarter lever is located on the right side of the engine. The engine can be started by kicking the lever with the ignition key in 'ON' position and engine kill switch '⌚' position**, while applying the rear brake as a safety precaution.

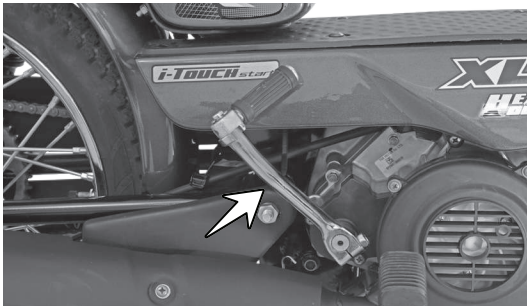

Warning

Hold the rear brake as a safety precaution while starting the vehicle to avoid rear wheel rotation and loss of control.

** Applicable for 'i-Touch Start' models only

STANDS

To place the vehicle on center stand (1), hold the handle bar left grip with the left hand and load carrier / pillion handle with the right hand.

Place your foot firmly on the center stand extension (1a) and press with adequate effort. Ensure both the legs of stand are touching the ground before placing the vehicle on stand.

TVS XL100 also has a provision for fixing a side stand (side stand is optional*). Side stand can be operated with your foot by pushing it away from the vehicle till it stops.

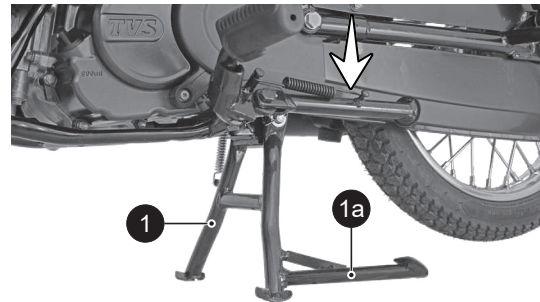

* Optional accessories will be charged extra

⚠ Warning

Always retract the side stand to its full up position before starting the vehicle. Else, the vehicle will get 'Switched OFF'. In key 'ON' & side stand deployed condition, continuous beep sound will be released from the vehicle to alert the rider to retract the side stand before starting the vehicle.

⚠ Caution

Never sit on the vehicle when it is supported by side stand. Always park the vehicle on a flat, firm surface.

HEAD LAMP FAIRING ASSEMBLY

TVS XL100 comfort vehicle comes with a stylish and elegant Head lamp Fairing assembly with LED DRL, ride brighter with the TVS XL100 Comfort.



TOOL BOX

Tool box is located below the seat assembly at the front end. To access the tool kit, first aid kit, fuse and battery the lid tool box need to be opened. Follow the procedure given below to open the lid:

1. Insert the control key into the lock of lid tool box and rotate it in anti-clockwise direction. Gently take out the lid from the tool box.
2. While reassembling locate the lid at the bottom of the tool box properly, press the top side firmly and then lock it by rotating the key in clockwise direction. Take out the key once the lid is locked.



SEAT LOCK*

To access the carrier*, the pillion seat assembly* need to be removed.

To remove the pillion seat assembly, insert the control key into the seat lock which is located at the left side rear end of the vehicle and rotate it in clockwise direction. Once the lock is released, gently take out the seat from its mounting.

To assemble back the seat back, locate the seat in the frame in its position and push it towards the front and then press down. Finally ensure the proper locking of the seat.

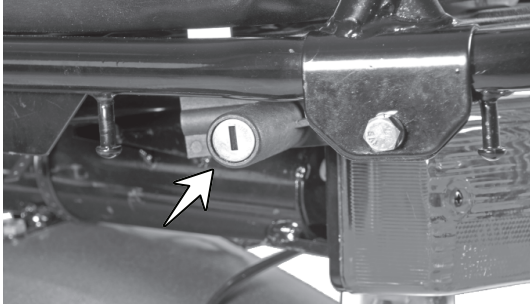

* Not applicable for Comfort models

TOOL KIT AND FIRST AID KIT

To assist you in performing certain aspects of periodic maintenance and emergency repairs, a tool kit is supplied along with the vehicle and it is located inside the tool box.

To access the tool kit and first aid kit, open the tool box lid as explained in the page No. 19.

The tool kit consists of the following :

- | | | |
|----|--------------------------|-----|
| 1. | Grip driver | x 1 |
| 2. | Bit (+) (-) | x 1 |
| 3. | 17 x 19 open end spanner | x 1 |
| 4. | Tool bag | x 1 |



i Note

It is recommended to use the tool kit in case of any emergency only. It is always advisable to take your vehicle to TVS Motor Company Authorised Main Dealer / Authorised Dealer.

SMART PHONE CHARGER#

A smart phone charger has been provided in your vehicle for charging your smart phone even when you are travelling and it is located in the cowl of speedometer. Follow the guidelines given below to use the charger properly.

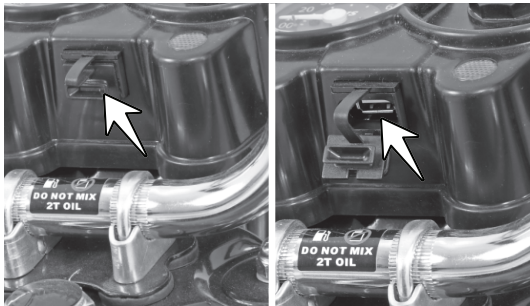

Do's

1. Ensure that no water enters into the USB charging unit by closing the flap properly and by avoiding the direct water jet towards the unit.
2. Use the USB charger only with standard approved USB charging cable recommended for your smart phone.
3. Do make sure the flap is not damaged while opening / inserting the USB cable.

Don'ts

1. Do not leave the USB charging flap open / partially closed.
2. Do not attempt to use / charge any other device, other than smart phone phones. Only one smart phone should be charged at a given time.
3. Do not try to force the USB connector in, check whether it is inserted in the appropriate direction, to prevent the damage to the charger.
4. Do not charge your smart phone when engine is off.

Applicable for selected models only

Before riding your vehicle, make yourself thoroughly familiar with all the controls of the vehicle and their functions.

Inspection before riding

- Check the following items before riding
 - Enough fuel for the planned distance of running.
 - MIL lamp goes OFF after engine start.
 - Proper working of electric start**.
 - Correct tyre pressure and adequate tread depth / no cracks or cuts.
 - Proper working of all lamps and horn.
 - Smooth movement of steering.
 - Smooth operation of throttle.
 - Correct free play of brakes.
 - Free rotation of wheels.

Starting the engine

Ensure the availability of adequate fuel in the fuel tank (low fuel indication shall not come ON). Insert the control key into the ignition lock and turn it to the 'ON' position. Retract the side stand. Turn the engine cut off switch** to the '⊙' position. Apply any one of the brake and press the electric starter switch** to start electrically or kick start.



Caution

In 'i-Touch Start' vehicles, in case if the ESIL lamp glows after switching 'ON' the ignition and while pressing the electric starter switch, turn 'OFF' the ignition and once again repeat the procedure of starting the vehicle using electrical starter. If the ESIL lamp still glows take the vehicle to TVS Motor Company Authorised Main Dealer / Authorised Dealer.

Press the electric starter switch without applying the throttle. The engine will not start if the throttle is opened full.



Note

Do not keep the engine in idling rpm for long and do not open excessive throttle when engine is idling, else it leads to overheating and damage to internal components.

** Applicable for 'i-Touch Start' models only

Riding

- After starting the engine, sit comfortably on the seat and open the throttle gradually. **Do not open throttle suddenly to full.**
- The clutch engages automatically.
- Keep your feet on the foot rest. From now on, your road speed is controlled only by throttle.
- Always keep to the left of the road. This will allow other fast moving vehicles to overtake you safely and easily.
- To overtake other vehicles, look ahead of you and into the rear view mirror to ensure that there are no vehicles close by. Then open the throttle and overtake from the right.

Stopping and parking

- Close the throttle completely. Apply both brakes simultaneously.
- Turn OFF the ignition.
- Park the vehicle on a firm, flat surface.
- Lock the steering and take out the control key.

FUEL RECOMMENDATION

Use only BS VI petrol with minimum RON 91.

BS VI petrol containing upto 10% of ethanol by volume can be used.

Higher ethanol content in petrol can

- degrade plastic and rubber components of fuel system and vehicle parts
- cause corrosion damage to metal parts like fuel tank, etc
- result in startability & drivability issues
- decrease fuel economy

Ethanol absorbs water very easily, resulting fuel separation. Extra care shall be taken to prevent moisture entry into fuel tank while filling ethanol blended petrol and water washing of vehicle. Painted parts (viz. panels, covers) shall not come in contact with ethanol blended fuels.

Manufacturer is not responsible for any warranty issues that results from using ethanol blend in excess of 10% by volume.

In case of any abnormalities observed due to use of ethanol blended fuels, customers are advised to use a different fuel station/brand for standard E10 fuel or contact authorised service centres.



Caution

Never mix oil in petrol in the fuel tank. Always fill fuel from the reputed and reliable fuel stations.

SOME USEFUL TIPS

Smooth riding

- Avoid engine idling for long period. It is better to switch it 'OFF' and start again.
- It is harmful to increase the engine speed with brakes applied as the engine gets unduly strained.
- Make your self familiar with the traffic signs and regulations.
- **For safe riding, it is advised to use a good quality helmet while driving.**
- **Avoid use of mobile phones while riding as it could lead to fatal accident.**

Improve service life of your vehicle

- Adhere to the recommended maintenance schedule and follow running-in information.
- Never drive the vehicle with low fuel as it damages the fuel pump.
- Apply brakes only when necessary.
- Always ride within the optimum speed range for better fuel economy.
- Avoid overloading.
- Avoid adjusting idling or any other fuel injection system related components.

FUEL ECONOMY

The maximum fuel economy is obtained between 30 to 45 km/h (indicated by a green zone on the speedometer). There is a drop in fuel economy both at lower speeds and even more at higher speeds. Frequent braking, long periods of idling and overloading will result in much lower fuel economy.

Tips to improve fuel economy

- Minimise braking and idling.
- Avoid sudden acceleration, applying brakes and throttle simultaneously and overloading.
- Inspect the tyre pressure regularly and inflate it to the recommended pressure (refer page No. 42).
- Ride in optimum road speed ie. 30 to 45 km/h.
- Perform maintenance as per the schedule.
- Use recommended oils and fuel only.
- Always maintain your vehicle in good state by getting it periodically serviced.
- Reduce petrol evaporation by parking your vehicle in shade.
- Reduce speed on bumps and rough roads.
- Anticipate the barriers ahead and decelerate at the earliest.

EMISSION CONTROL

All the TVS vehicles are tested in the factory for optimum fuel efficiency and CO levels. If any abnormality, please consult nearest TVS Motor Company Authorised Main Dealer or Authorised Dealer.

While adequate care is exercised at the factory to ensure that the emissions are within the limits, it is essential for the owner to always maintain their vehicles in good condition by getting it periodically serviced and checked by TVS Motor Company Authorised Main Dealer or Authorised Dealer so that the emission and fuel consumption level are maintained as per norms.

Crankcase emission control system

The engine of TVS XL100 is equipped with a closed crankcase system to prevent discharging crankcase emissions into the atmosphere. Blow-by gas is returned to the combustion chamber through the air cleaner and the fuel system.

Evaporative Emission Control System

TVS XL100 is equipped with an evaporative emission control system which consists of a canister and associated piping. This system prevents the escape of fuel vapors from the fuel tank.

Warning

If there is any abnormal jerk, startability issue are felt in the vehicle or noise due to sudden escape of gas during opening of fuel tank cap, immediately report to the TVS Motor Company Authorised Main Dealer / Authorised Dealer.

Note

Your vehicle is tested and certified for emission which meets BS VI emission norms and is valid for initial 12 months from the date of purchase. Get your vehicle certified by the Government authorised emission testing station after initial 12 months of usage. And ensure to get the vehicle certified on expiry of the certificate obtained.



MAINTENANCE SCHEDULE

The maintenance schedule indicates the intervals between periodic services. At the end of each interval, be sure to inspect, check, replace, adjust, lubricate and service as instructed. If the maintenance is not done periodically, it will result in rapid wear and severe damage to the vehicle. If the vehicle is used under high stress conditions such as continuous full throttle operation or if used / operated in dusty climate, certain jobs should be performed more often to ensure reliability of the vehicle. Fi system, cylinder head, steering components, suspension, chain and wheel components etc., are key items and require very special and careful servicing. TVS Motor Company Limited strongly recommends that the jobs as per the maintenance schedule be performed by your TVS Motor Company Authorised Main Dealer / Authorised Dealer.

Periodic inspections may reveal one or more parts that may need replacement. Whenever replacing parts on TVS XL100, it is recommended that you use only the **TVS Motor Company Genuine** parts.



Caution

Proper running-in and maintenance are mandatory for making certain that your vehicle is reliable and gives optimum performance at all times. Be sure that the periodic maintenance is performed thoroughly in accordance with the instructions given in this owner's manual.

In more dusty areas, the air filter element may required early replacement than the mentioned kilometers to avoid costly damages to the engine.



PERIODIC MAINTENANCE SCHEDULE (months or km whichever occurs earlier)

Item	Service km Period from the date of sale	In free service			After free service		Remarks
		1st 500 - 750 1 months	2nd 2500 - 3000 3 months	3rd 5000 - 6000 6 months	Every 3000 km 3 months	Every 6000 km 6 months	
Engine cum transmission oil		R	I & T	R	I & T	R	
Oil filter (strainer)		C	-	C	-	C	
Centrifugal filter		-	-	C	-	C	
Spark plug		I	-	-	-	-	Inspect, Clean and adjust if required, Replace every 12000 km
Air cleaner element		I	-	-	-	-	Replace every 9000 km
SAI filter element		I	-	-	-	-	Replace every 12000 km
Fuel filter assembly and pencil filter in fuel pump		-	-	-	-	-	Inspect and check every 24000 km Replace every 24000 km
Tappet clearance		I	-	I & A	-	I & A	Inspect for any noise / starting trouble and adjust if required
Hose fuel		-	-	-	-	-	Replace every three years or 30000 km
EVAP hoses		-	-	-	-	-	Replace every three years or 30000 km
All control cables and lever ¹		I & A	I, A & L	I & A	I & A	-	Lubricate every 6000 km after free services
Throttle grip		-	-	L	-	L	Lubricate using grease if necessary
Steering smooth operation / play		I & A	I & A	I & A	I & A	-	C & L with fresh grease every 12000 km
Front fork oil		-	-	-	-	-	Replace every 12000 km

R - Replace; I - Inspect; T - Top up; C - Clean; A - Adjust; L - Lubricate; TI - Tighten; S - Set

¹ Inspect for proper operation and adjust play. Lubricate ends using grease.

Contd...

Item	Service km Period from the date of sale	In free service			After free service		Remarks
		1st 500 - 750 1 months	2nd 2500 - 3000 3 months	3rd 5000 - 6000 6 months	Every 3000 km 3 months	Every 6000 km 6 months	
Front and rear suspension		I	I	I	I	-	Inspect for proper functioning
Speedometer hub drive / cable		-	-	L	-	L	Lubricate using grease if necessary
Brake cams / SBT system parts		-	-	C & L	-	C & L	Lubricate using grease
All fasteners		I & TI	I & TI	I & TI	I & TI	-	
Drive chain ²		C, L & A	C, L & A	C, L & A	C, L & A	-	
All bulbs, horn and switches		I	I	I	I	-	Inspect for proper functioning
Head lamp beam		I	I	I	I	-	Adjust if necessary
Battery voltage		I	I	I	I	-	Recharge if necessary
Brake effectiveness / play		I & A	I & A	I & A	I & A	-	
Wheel freeness		I	I	I	I	-	
Wheel spokes		I & TI	-	I & TI	-	I & TI	
Tyre pressure in cold condition		I & S	I & S	I & S	I & S	-	
Center / side stand pivot / Kick starter pedal pivot		L	L	L	L	-	Lubricate using TRU4 oil
Malfunction indicator lamp		I	I	I	I	-	<i>Check and resolve the errors using diagnostic tool if the lamp is ON even after starting the engine</i>
Engine idling speed		-	-	-	-	-	Inspect incase of any abnormality

R - Replace; I - Inspect; T - Top up; C - Clean; A - Adjust; L - Lubricate; TI - Tighten; S - Set

² Clean the drive chain and apply TRU SPRAY / TRU4 oil as frequently as every 750 kms and adjust when necessary for better chain life and smooth vehicle running.

RECOMMENDED LUBRICANTS

APPLICATION	QTY	MANUFACTURER	BRAND
Engine cum transmission oil	900 ml	TVS Motor Company	TVS TRU4 PREMIUM oil (SAE 10W30 API-SL, JASO MA2)
Front fork oil	100 ml / leg	IOC / Castrol	20W40 oil
	210 ml / leg*	IOCL / HPCL / BPCL*	ETL 1F*
Grease	-	Bharat petroleum	MP Grease no. 3
		IOC	Servo Gem no. 3
		Bechem	Bechem premium 3
Chain lubricant	-	TVS Motor Company	TRU SPRAY

* Applicable for 'XL100 comfort' models only

SELF-MAINTENANCE PROCEDURES

BATTERY

TVS XL100 'i-Touch Start' vehicles are fitted with a maintenance free battery and it is located inside the tool box below seat at front side of the seat.

Remove the lid tool box, cover tool box and cover battery to access the battery by following the procedure given below:

1. Remove the lid tool box as explained in page No. 19.
2. Remove the top mounting screws (A) from both the sides of tool box.

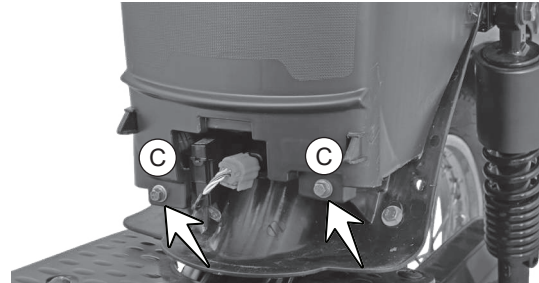
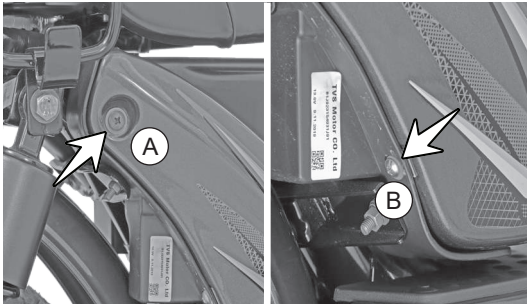

3. Similarly, remove the bottom mounting screws (B) from both side of tool box and take out the tool box.
4. Remove the mounting bolts (C) from the cover tool box and gently take out the cover.

To ensure the performance and long life of the battery follow the steps given below:

- Check and ensure the battery voltage as per the maintenance schedule given in page No. 27.
- If the voltage measured is less than 12.4 Volts, charge the battery using recommended battery charger at TVS Motor Company Authorised Main Dealer / Authorised Dealer.

- In maintenance free (MF) type battery, it is not required to top-up the battery with distilled water.
- While connecting the terminals, observe the correct polarity. Connect the red wire to the '+' terminal and black wire to the '-' terminal of the battery.
- Apply petroleum jelly at terminals to prevent it from corrosion.
- Do not add any additional electrical accessories which may affect the battery life and also results in startability issue.

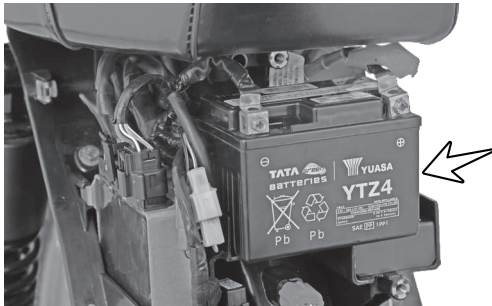

In case of any abnormality or for removal of battery from the vehicle, contact TVS Motor Company Authorised Main Dealer / Authorised Dealer.

 **Caution**

Never check the battery charge by shorting the terminals. Always connect the positive terminal first (red wire) and then negative (black wire) to avoid sparking.

The inversion of the battery wires can damage the battery and the recharging system.

If the battery is removed from the vehicle, please ensure to tape the terminals of the wiring harness to avoid the terminals make contact with each other / ground which will prevent the vehicle from starting.

Recommendations to maintain battery health during prolonged parking conditions

While your vehicle is parked for prolonged duration, battery continues to discharge and if left unattended can get completely discharged. It is recommended to ride the vehicle for minimum 60 km every week to keep the battery in healthy condition. This could be at a stretch in one ride or several rides during the week.

The vehicle speed will vary during the ride but an average speed of minimum 30 kmph will be helpful to ensure proper battery charging. Use kick-starting, if available, to conserve battery charge during such period. This is only a recommendation to maintain battery charge and regular service schedules must be followed to maintain your vehicle in good running condition.

The following is recommendations to users regarding battery maintenance before, during and after long storage of battery:

1. Before Storage

- a. Store the battery only after fully charging it
- b. Battery fuse to be disconnected and stored safely. This will reduce the sleep mode current and hence enhance storage life of battery.*

- c. Alternatively, battery connecting wires (positive and negative wires) can be disconnected and fasteners can be secured with battery terminals.*

2. During Storage

- a. Store it at room temperature or lower.
- b. Store the vehicle in the shade and protected from rain and cover the vehicle to prevent rodents from entering and damaging the wires.

3. After Storage

- a. Connect the wires and fuse, if disconnected earlier, with ignition switch in OFF position*
- b. Start the vehicle by kick starting.

(Above recommendations do not consider storage effects on other systems such as induction and fuel systems and wheels)

** To be done by skilled personnel*

Periodic Maintenance of Batteries:

- Keep top of battery clean
- Check cables, clamps, and case for obvious damage or loose connections
- Clean terminals and connectors as necessary
Recharge battery if voltage is below 12.4V.

Valve Regulate Lead Acid (VRLA) / Lead Acid batteries are prone to water damage. Any water entry, through vents or otherwise; will result in irreparable damage to the battery or the vehicle.

Warning

Battery develop explosive gases. Keep it away from heat sources. If charging is required the battery must be charged in well ventilated area.

Unusable battery must be disposed in environment friendly manner. Do not discard it with household trash. Handover the battery to the battery dealers or to a recycle center that accept used battery.



Caution

Never operate the vehicle with discharged battery as it may damage electrical components.

Do not push start the vehicle, use a good battery to start the vehicle.

FUSE REPLACEMENT

Non-working of electrical systems may be due to safety fuse failure. Short circuit or overload in the electrical system are the main causes for fuse failure. Two different fuses are provided in the XL100 they are:

- Main fuse - 15A
- Lighting fuse - 10A

The main fuse is located inside the tool box below battery and the lighting fuse is located inside the head lamp.

Follow the procedure given below to inspect and replace the fuse:

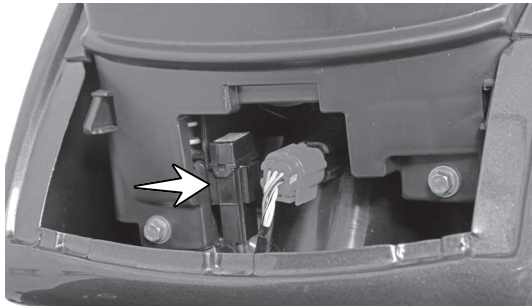

Main fuse

1. Turn 'OFF' the Ignition.
2. Remove the lid tool box as explained in page No. 19.
3. Take out the fuse case.
4. Open the fuse case and pull out the blown fuse.
5. Replace the blown fuse with a new (extra fuse is provided in the wiring harness itself in a pouch).
6. Close the fuse case and re-fix it properly into its location.
7. Turn 'ON' the ignition lock and check for proper functioning of the electrical systems. In case the fuse fails again, consult the nearest TVS Motor Company Authorised Main Dealer / Authorised Dealer.

Good Fuse

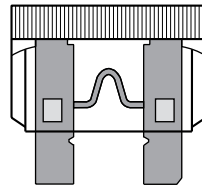

Blown Fuse

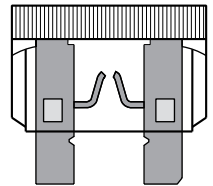

Lighting fuse

1. Turn 'OFF' the Ignition.
2. Remove the screws from the head lamp housing assembly on both sides and gently take out the reflector unit.

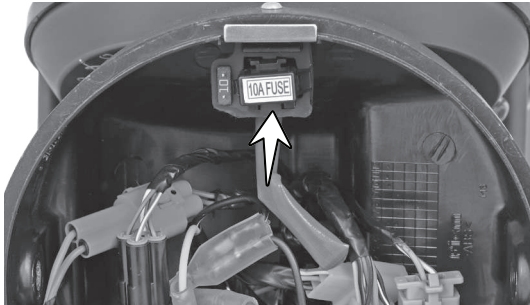

Caution

Do not use vehicle by **shorting the wires without fuse**. This may result in overheating of electrical items / wiring and may result in fire.

Do not use fuse of higher amperage than specified for the safety of electrical system.

3. Take out the fuse case from the housing head lamp.
4. Open the fuse case and pull out the blown fuse.
5. Replace the blown fuse with a new (extra fuse is provided near the fuse case itself).
6. Close the fuse case and re-fix it properly into its location.
7. Turn 'ON' the ignition lock and check for proper functioning of the electrical systems. In case the fuse fails again, consult the nearest TVS Motor Company Authorised Main Dealer / Authorised Dealer.
8. Re-fit the reflector unit.

SPARK PLUG

1. Pull out the suppressor cap from the spark plug.
2. Clean the dust and mud around the spark plug mounting to avoid falling inside the cylinder.
3. Remove the spark plug.

Inspect the spark plug for heavy carbon deposits, a spark plug with heavy carbon deposits will not produce strong sparks. Hence, remove the carbon deposits from the spark plug with a small wire brush or using spark plug cleaning tool.

Inspect the spark plug electrodes (A) and (B) for any corrosion. If found any, replace the spark plug with a new.

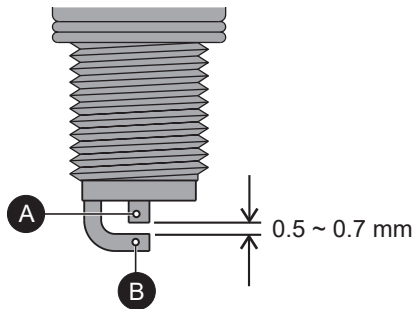

Inspect the spark plug gap with a wire gauge / feeler gauge. Readjust the spark plug gap to **0.5 ~ 0.7 mm** if required.

After cleaning and adjusting the gap, reinstall the spark plug and tighten by hand to avoid cross threading. Finally tighten using spark plug spanner. Do not over tight or cross thread the spark plug.

Caution

*Always use only recommended make and type of spark plug. **Replace the spark plug every 12000 km.***

Don't remove the spark plug when the engine is hot. Cover the spark plug hole with a cloth when the plug is removed to prevent entry of dust / water.

It is advisable to tighten the new spark plug by hand till the end, using plug spanner tighten by 1/4 turn. Then loosen the plug by 1/8 turn and re-tighten using plug spanner.

ENGINE CUM TRANSMISSION OIL LEVEL

Check the engine cum transmission oil level periodically.

1. Place the vehicle on center stand on a flat surface. Wipe-off the surroundings of the gauge oil level.
2. Remove the gauge oil level and wipe it clean.
3. Fix the gauge oil level back to its mounting hole. Do not thread in.
4. Take out the gauge oil level and check the level of the oil.
5. The oil level should be between minimum and maximum level marks of the gauge as shown in the figure.

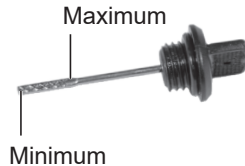
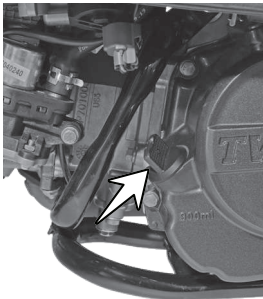

6. If the oil level is less than the minimum level, add 'TVS TRU4 PREMIUM oil (SAE 10W30 API-SL, JASO MA2)' upto the maximum level mark.
7. Wipe out the oil traces with a clean cloth to prevent dust accumulation and assemble back the gauge oil level.



Caution

If the vehicle is driven with less engine cum transmission oil, engine components will be severely damaged. Check the oil level as per the schedule to avoid costly damage.

Do not fill excess oil may cause oil leak. Always use 'TVS TRU4 PREMIUM oil (SAE 10W30 API-SL, JASO MA2)' only.

BRAKES

Right hand brake lever

1. Measure the free play of the right hand brake lever at the lever end as shown in the figure.
2. The free play of the brake lever before the engagement of the brake should be between 10 ~ 15 mm.

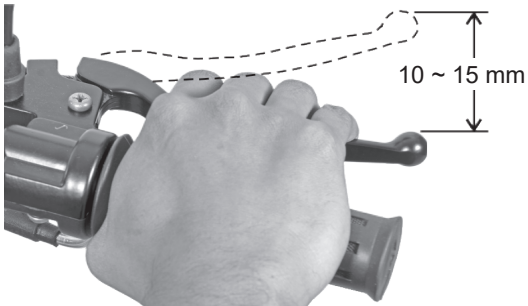

3. Slightly loosen the adjuster nut at top (2).
4. Turn the adjuster nut at bottom side (1) in the slot marked as 'I' in clockwise direction for reducing the free play or in anti-clock wise direction for increasing the free play

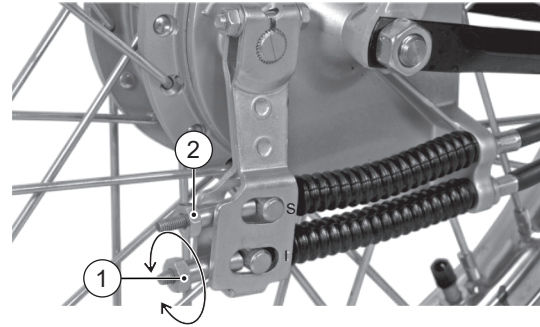

Warning

Since the vehicle is fitted with Synchronized Braking Technology (SBT) adjust the brakes with additional care. If not it may result in brakes not working properly.

Please contact TVS Motor Company Authorised Main Dealer or Authorised Dealer for any further assistance.

SBT
SYNCHRONIZED BRAKING
TECHNOLOGY

5. After obtaining the necessary free play at the lever end, inspect for the clearance between the bullet (3) and slot end (4) marked as 'S' as shown in figure.
6. If any clearance is found then turn the adjuster nut (2) at slot marked as 'S' in clockwise direction until there is no clearance between the bullet (3) and slot end (4).
7. After adjusting the adjuster nut (2), If any clearance is observed in between the bullet (5) and slot end (6) marked as 'I' as shown, then turn the adjuster nut (2) in anti-clockwise until the clearance is closed.

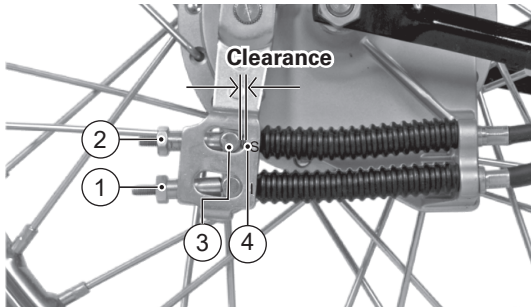

8. Once again check and confirm the brake play at the lever end.

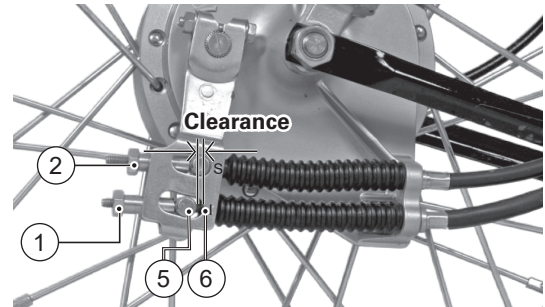

Left hand brake lever

1. Measure the free play of the left hand brake lever at the lever end as shown in the figure.
2. The free play of the brake lever before the engagement of the brake should be between 15 ~ 20 mm.

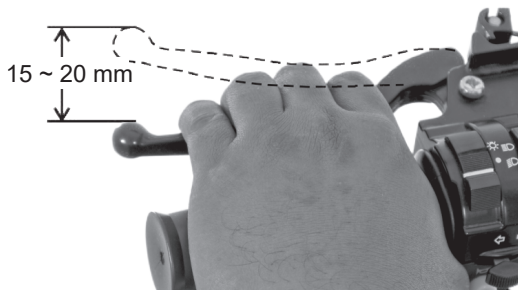

3. If the measured free play is more or less than the specified limit, adjust the nut provided at the rear wheel end to obtain the correct play.
4. Turn the adjuster nut in clockwise direction for reducing the free play or turn it in anticlockwise direction for increasing the free play.

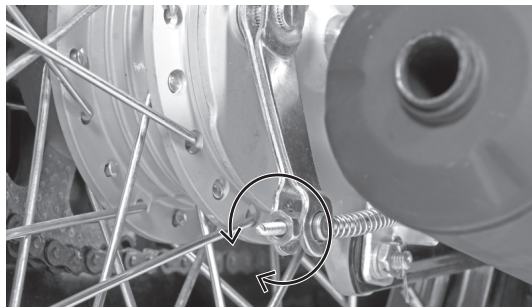

i Note

Please remember that the rear brake lever free play adjustment to be done only after adjusting the front brake lever play.

Brake shoe wear indicator

When the brake is applied, wear limit index mark (A) on both front and rear cam brake should be within the range of wear limit indicator (B) on panel assembly. In case the index mark (A) is going beyond the wear limit (B), replace the brake shoes as a complete set, with the help of the nearest TVS Motor Company Authorised Main Dealer / Authorised Dealer.

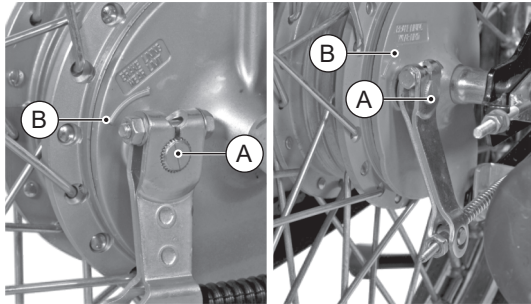

Caution

Replace the brake shoes as a set, if wear limit index mark (A) exceeds beyond the range of wear limit indicator (B) even after indexing the lever.

However, if cam lever adjustment goes beyond certain range then index the cam lever to next slot (serration tooth) with the help of the nearest TVS Motor Company Authorised Main Dealer / Authorised Dealer to utilize remaining shoe life until wear limit index mark (A) exceeds beyond the range of wear limit indicator (B).

TYRES

Tyre pressure

Check the tyre pressure atleast once in a week if not more frequently. Insufficient air pressure in the tyres not only hasten tyre wear, but also seriously affects the stability of the vehicle.

Under inflated tyres make smooth cornering difficult and over inflated tyres decrease the tyre contact with the ground which can lead to skidding and loss of control. Be sure that the tyre pressure is within the specified limits at all times.

	Solo	Dual
Front	1.75 kg/cm ² (25 PSI)	1.75 kg/cm ² (25 PSI)
Rear	2.46 kg/cm ² (35 PSI)	2.81 kg/cm ² (40 PSI)

Tyre tread condition

Operating the vehicle with excessively worn tyres will decrease riding stability and can lead to loss of control. It is recommended to replace the tyre when the tyre wears off to the tyre wear indicator (A) level (indicated by TWI on the tyre).



Warning

The tyre inflation pressure in cold condition and the tyre tread condition are extremely important for the performance and safety of the rider. Check the tyres frequently for inflation pressure as well as the wear pattern on it.

Use of a tyre other than the standard may cause instability.

Tyre Maintenance Tips

Inflation Pressure Check - Condition

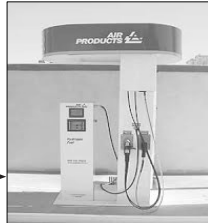

Within
1 km

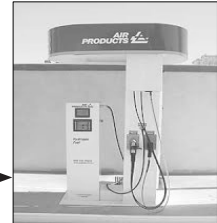

Within
5 km

i Note

If vehicle is in hold condition for long time

- *Need movement of vehicle to avoid particular spot of tyre not to touch the ground for more than week time.*
- *Inflation pressure should check on cold condition maximum travel time should not exceed more than 1 km.*
- *Weekly basis inflation pressure check helps to improve 10% of tread life & fuel efficiency.*

REAR SHOCK ABSORBERS

TVS XL100 is provided with 5 step adjustable rear shock absorbers to meet different load condition. There are 5 notches for adjusting spring load. If the spring is adjusted to the minimum notch, then the shock absorber will be softer which is good for light loads. If the spring is adjusted to maximum notch, then it will be stiffer which is good for heavy loads. Adjust the spring pre-load by shifting the adjuster to the required notch according to the different load condition. The more you compress the shock absorber spring, the suspension becomes more stiff.

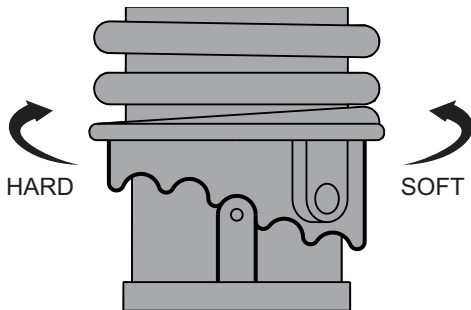
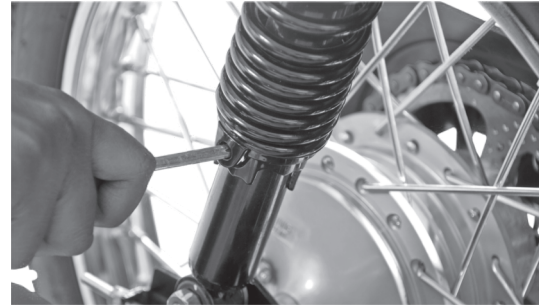

Caution

Keep both left and right shock absorbers spring adjusters in the same position.

DRIVE CHAIN

Proper lubrication and adjustment of drive chain gives long service life of chain. Poor maintenance of chain causes premature wear or damage to the drive chain and sprockets.

The drive chain must be checked, lubricated and adjusted at specified intervals mentioned in the maintenance schedule.

If the vehicle is used under severe conditions and more dusty area, the drive chain must be attended more frequently. Get the drive chain checked, lubricated and adjusted at TVS Motor Company Authorised Main Dealer / Authorised Dealer at specified intervals if required more frequently depending upon usage.

FRONT WHEEL REMOVAL

1. Remove the hexagonal nut along with washer from any one side of the front wheel axle.
2. Pull out the axle from the wheel along with the hexagonal nut and a washer.
3. Place a support (wooden block) below the engine to prevent the vehicle from falling.
4. Lift the front fork up, dislocate the brake panel along with the brake cable. Remove the hub drive and slide the wheel out.
5. Reverse the procedure for reassembling. Locate the lug on fork leg L to the slot in the brake panel while reassembling.

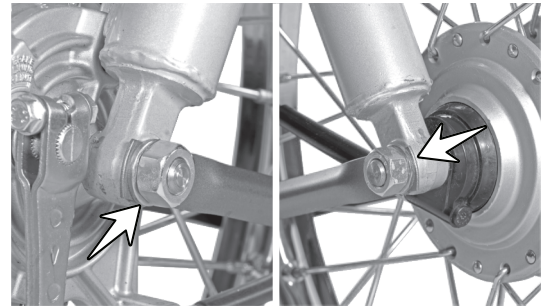

⚠ Warning

Always make sure that whenever the wheel is removed, axle nut is properly re-tightened to the specified torque.

REAR WHEEL REMOVAL

1. Remove the rear brake adjuster nut (1) and disconnect the brake cable from the brake panel assembly.
2. Remove the split pin (2) and the nut (3). Disconnect the torque link.
3. Remove the axle nut (4).
4. Pull out the axle (5) and take out the spacer from the rear wheel assembly.

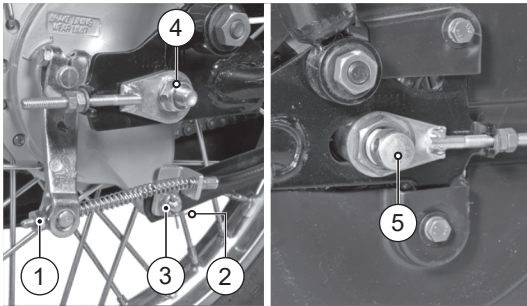

5. Tilt the vehicle to the left and take out the wheel assembly along with the brake panel assembly.
6. Reverse the procedure for reassembly.

⚠ Caution

Once the split pins are removed, replace them with new ones.

STORAGE PROCEDURES

For storage of your vehicle for longer periods of over a month and above, we recommend to carry out the following steps:

1. Clean the vehicle thoroughly. Park the vehicle on center stand.
2. Empty the fuel tank.
3. Warm up the engine and drain engine cum transmission oil. Store the oil, if new, in a dust free container.
4. Remove the spark plug and feed in several drops of engine cum transmission oil through spark plug hole. Crank the engine few times and reinstall the spark plug.
5. Remove the battery, store it away from direct sunlight and freezing temperatures.

6. Place a suitable support at the bottom of the frame so that both the tyres are off the ground. This will ensure better tyre life.
7. Cover up the vehicle completely with a clean tarpaulin or any other suitable cover. Store the vehicle inside a garage or similar area to avoid damage due to dust and rain. Make sure that the storage area is well ventilated and free from any source of flame or spark.

 **Warning**

The exhaust system becomes hot after a run. Park the vehicle in a place where pedestrians or children are not likely to touch the vehicle.

 **Caution**

Do not park the vehicle on a slope or soft ground or else it may fall down.

TAKING THE VEHICLE OUT OF STORAGE FOR REGULAR USE

1. Take the vehicle out of the garage and clean it thoroughly.
2. Remount the battery after bench charging if required.
3. Fill the engine cum transmission oil [TVS TRU4 PREMIUM oil (SAE 10W30 API-SL, JASO MA2)] and check the level using gauge oil level.
4. Lubricate the parts as instructed in the periodic maintenance schedule.
5. Fill up fresh petrol in the fuel tank.
6. Check and inflate the tyres to the specified tyre pressure.
7. Turn the ignition switch to 'ON' position. Retract the side stand if the vehicle is parked on side stand. Start the engine and run in idle for a few minutes and ride out.

 **Caution**

Avoid using alkaline solution like detergent soaps for washing. This may damage head lamp and other lamp assemblies.



Drive In.

Drive Out.



**Say bye-bye to waiting time
for servicing your bike.**

Get your vehicle serviced in 1 hour at no additional cost. Contact your nearest Dealership for details.[†]

[†]Facility available at selected Dealerships only. Terms and conditions apply





Busy Life? Easy Servicing!

Now, service your bike anywhere, anytime.

- ★ Service the vehicle at your door step.
- ★ Available for regular maintenance or breakdown service only.
- ★ Offered at nominal convenience charges.

Contact your nearest Dealership for details.[†]

[†]Facility available at selected Dealerships only. Terms and conditions apply

TVS 
**geared
to care**
*Pickup &
Drop*

Busy Life? Easy Servicing!

Now, service your bike anywhere, anytime.

- ★ Service the vehicle at your door step.
- ★ Available for regular maintenance or breakdown service only.
- ★ Offered at nominal convenience charges.

Contact your nearest Dealership for details.[†]

[†]Facility available at selected Dealerships only. Terms and conditions apply



TVS Motor Company Limited ('the Company') give this warranty with respect to the TVS XL100 HEAVY DUTY i-TOUCH start / TVS XL100 COMFORT i-TOUCH start / TVS XL100 HEAVY DUTY / TVS XL100 COMFORT / TVS XL 100 manufactured by the Company.

While the Company has taken every care to maintain quality in the manufacture of the TVS XL100 HEAVY DUTY i-TOUCH start / TVS XL100 COMFORT i-TOUCH start / TVS XL100 HEAVY DUTY / TVS XL100 COMFORT / TVS XL 100, the above said warranty is subject to other terms of warranty:

During 3 Years from the date of purchase or during the first 36,000 km of run for the vehicle in the hands of original retail purchaser, whichever is earlier, the parts of the vehicle covered under warranty which prove to the satisfaction of the Company to have a manufacturing defect will be repaired or replaced free of cost.

The Company's obligation under this warranty is limited to repairing or replacing, free of cost, those parts of the vehicle which upon examination by the Company may prove to the Company's satisfaction to have a manufacturing defect, and in such cases the Company's decision either to repair or replace the affected parts will be final. In the event of replacement of parts, the Company also reserves the right to use parts of the same brand as the affected parts or any other brand which is used by the Company in the course of manufacture. All parts replaced under this warranty will become the property of the Company and must be returned to the company.

Limitations of Warranty:

This warranty shall not apply to following condition:

1. Any natural wear and tear, including without limitation, aging.
2. Warranty claims on proprietary items such as tyres, tubes and batteries etc., should be preferred by the user directly on the respective manufacturer, as per their warranty terms and the Company shall not be liable in any manner in respect to the same.
 - Battery warranty for "MF type (Maintenance Free)" is applicable for a period of 21 months from the date of charging or 18 months from the date of sale or 20,000 kms, whichever is earlier.
 - Battery warranty for "Lead Acid type" is applicable for a period of 15 months from date of charging or 12 months from date of sale or 10000 kms whichever is earlier.
3. Parts repaired or replaced under this warranty are warranted only throughout the remainder of the original warranty period.

4. The Company is not liable for any delay in servicing due to reasons beyond the control of the Company or any of its Authorised Main Dealers / Authorised Dealers.
5. In any event, the Company is not liable for indirect, remote, incidental or consequential damages.
6. The Company may make any modification or improvement to vehicles in future production at any time without prior notice and without any obligation to install the same on vehicles previously dispatched for sale.
7. Any claim under this warranty will lie only when the customer:
 - takes his vehicle to an Authorised Main Dealer / Authorised Dealer of the Company and reports the problem he / she felt in the vehicle to enable the Authorised Main Dealer / Authorised Dealer to inspect the same and assess the cause for the reported problems.
 - produces to such Authorised Main Dealer / Authorised Dealer the Service Handbook for the concerned vehicle for verification of relevant details.
8. This is the only warranty given by the Company for the TVS XL100 HEAVY DUTY i-TOUCH start / TVS XL100 COMFORT i-TOUCH start / TVS XL100 HEAVY DUTY / TVS XL100 COMFORT / TVS XL 100. No employee, Dealer or other person is authorised to extend or enlarge this warranty.

Warning

Modifications to this vehicle not approved by the TVS Motor Company may cause loss of performance and render it unsafe for use and disqualifies for warranty coverage also.

Following Toll Free numbers can be contacted for battery related queries if any.

Incase of EXIDE battery, call :- 1800 103 5454

Incase of AMCO battery, call :- 1800 425 0096

Incase of TATA GREEN battery, call :- 1800 419 8888

Incase of AMARON battery, call :- 1800 425 5858

Following Toll Free numbers can be contacted for Tyre related queries if any.

Incase of TVS Srichakra, call :- 04522443300

Incase of JK tyre, call :- 18002581100

Incase of Maxxis tyre, call :- 1800 532 2888

List of parts not covered under warranty

ITEM	WHAT TO CHECK FOR
Normal Maintenance Operations	Engine tune-up, decarbonizing, fuel system cleaning, oil changes, head light focusing, fastener retightening, ignition timing, clutch and brakes as well as other normal adjustments.
Wear and Tear Items	Chain, sprockets, clutch and brake linings, fasteners, shims, washers, oil seals, gaskets, O' rings and spokes etc.
Electrical	Bulbs , fuse, DRL, brake switch
Service Maintenance Parts	Oil filters, spark plug, air filter, SAI filter, oil and brake fluid
Rubber, Rexine and Plastic Items	All hoses , pipes and plastic aesthetics
Proprietary Items	<p>Battery, tyres and tubes (the warranty terms are subject to our agreement with proprietary OEM)</p> <p>(Battery warranty for "MF type (Maintenance Free)" is applicable for a period of 21 months from the date of charging or 18 months from the date of sale or 20,000 kms, whichever is earlier).</p> <p>(Battery warranty for "Lead Acid type" is applicable for a period of 15 months from date of charging or 12 months from date of sale or 10000 kms whichever is earlier).</p>
Others Factors	Parts of the vehicle getting affected due to atmospheric effect / environmental factors (rusting, paint peel off etc.). However, depending on the vehicle usage condition, warranty would be accepted up to 2 years from the date of purchase.
	Parts of the vehicle which have been tampered with, altered, repaired or replaced by persons not authorised by the Company and which in the sole judgement of the Company affect the performance of the vehicle.

List of parts not covered under warranty

ITEM	WHAT TO CHECK FOR
Others Factors	Parts which are used in conjunction with parts not made or recommended by the Company.
	Parts suffering damage or resultant damage by accident, misuse, negligent treatment, use of bad quality lubricants or impure fuel or by omission to follow the guidance and instructions contained in this owner's manual.
	Vehicles on which engine number or chassis number is deleted, defaced or altered.
	Vehicles on which any warranty service including scheduled paid service is not availed when it falls due (at TVS Motor Company Authorised Main Dealer / Authorised Dealer).
	<p>Vehicles sold or transferred by original retail purchaser.</p> <p>Vehicles used for racing or any competition or used otherwise than for ordinary personal transportation. Vehicles attached with side cars etc.</p> <p>Vehicles which have been taken out of India.</p> <p>Vehicles affected by natural calamities like flood, earthquake, tsunami, storm etc.,.</p>
	If the vehicle has been used for commercial purpose like taxi or used for rental or hiring or any other purpose other than regular personal transportation.

SERVICE INFORMATION

There are thirteen services for TVS XL100 HEAVY DUTY i-TOUCH start / TVS XL100 COMFORT i-TOUCH start / TVS XL100 HEAVY DUTY / TVS XL100 COMFORT / TVS XL 100 vehicle during warranty period. Of these, first three services are free services for which labour charges are free. In addition to these three free services, we have a scheme of ten pay services. For keeping maintenance track of your vehicle, a free and pay service record sheets are attached with this Service Handbook. Please have the record sheets filled by the Dealer who is carrying out the maintenance service.

For availing any of the thirteen warranty services, please take your vehicle and your Service Handbook to any of our Authorised Main Dealer or any of our Authorised Dealer. After effecting the service the Authorised Main Dealer or the Authorised Dealer will affix their stamp on the last column of the free or pay service record sheet for your record and reference. An OTP would be sent to customer's registered mobile number. The same to be shared with the servicing Dealer on or before vehicle delivery.

Periodic maintenance always helps good performance of an automobile and our services are planned to keep your TVS XL100 vehicle performing good. **Please note that carrying out the services for your vehicle at scheduled intervals at any of the TVS Motor Company Authorised Main Dealer / Authorised Dealer is necessary for availing of warranty.** And please also remember that, after the services are over, periodic servicing of your vehicle at appropriate intervals, depending upon its extent of use, will keep your vehicle at its best level of performance.

In case you need any clarification or assistance, please feel free to write to us mentioning the frame number, engine number and the date of purchase of your vehicle also the name and place of the Authorised Main Dealer / Authorised Dealer from whom you bought the vehicle and getting it serviced.

Service Department

TVS MOTOR COMPANY LIMITED

P.O. Box No. 4, Harita, Hosur - 635 109,

TAMILNADU, INDIA.

Toll free no:- 1800-258-7111

PLANNED SERVICE SCHEDULE (kms or month whichever of the two occurs early)

Sl. No.	SERVICE	TYPE	Kms	MONTHS
1	1st service	Free	500 ~ 750	1 month
2	2nd service		2500 ~ 3000	3 months
3	3rd service		5000 ~ 6000	6 months
4	4th service	Pay	8500 ~ 9000	9 months
5	5th service		11500 ~ 12000	12 months
6	6th service		14500 ~ 15000	15 months
7	7th service		17500 ~ 18000	18 months
8	8th service		20500 ~ 21000	21 months
9	9th service		23500 ~ 24000	24 months
10	10th service		26500 ~ 27000	27 months

i Note

Free services enables the customer to avail the service at free of labour charges. Charges for the pay service should be borne by the customer. Cost of engine oil, periodic maintenance parts, filter, all types of greases, petroleum jelly, distilled water, chain cleaner, lubricants, coolants, cleaning cloths for both free and paid services are chargeable to the customer.

SI. No.	SERVICE	TYPE	Kms	MONTHS
11	11th service	Pay	29500 ~ 30000	30 months
12	12th service		32500 ~ 33000	33 months
13	13th service		35500 ~ 36000	36 months

Please remember that, after the above schedule, periodic servicing of your vehicle at appropriate intervals, depending upon its extent of use, will keep your vehicle at its best level of performance.

DESCRIPTION	TVS XL100 HEAVY DUTY i-TOUCH start / TVS XL100 COMFORT i-TOUCH start / TVS XL100 HEAVY DUTY / TVS XL100 COMFORT / TVS XL 100
MANUFACTURER	<p style="text-align: center;">TVS MOTOR COMPANY LIMITED P.B. No. 4, Harita, Hosur - 635 109, India.</p> <p style="text-align: center;">TVS MOTOR COMPANY LIMITED P.B. No1, Bythahalli, Kadakola post, Mysore - 571 311, India.</p>
ENGINE	
Type	Single cylinder, 4 stroke, fuel injection, air cooled, spark ignition engine
Cylinder bore	51 mm
Stroke	48.8 mm
Piston displacement	99.7 cc
Compression ratio	10.3 : 1
Air filter	Paper filter element
Lubrication system	Forced lubrication
Maximum power in kW	3.2 (4.3 bhp) @ 6000 rpm
Maximum torque in Nm	6.5 @ 3500 rpm
	58 km/h
Engine idling rpm	1550 ± 100 rpm (under warm condition)
Starting system	Kick starter / Electric starter*
Emission norms	BS VI

** Applicable for 'i-Touch Start' models only



DESCRIPTION	TVS XL100 HEAVY DUTY i-TOUCH start / TVS XL100 COMFORT i-TOUCH start / TVS XL100 HEAVY DUTY / TVS XL100 COMFORT / TVS XL 100
TRANSMISSION	
Clutch	Centrifugal shoe type wet clutch
Primary transmission	Single speed gear box
Secondary transmission	Chain and sprockets
Final reduction	13.87 : 1
CHASSIS	
Overall length	1895 mm
Overall width	670 mm
Overall height	1077 mm
Ground clearance (unladen)	145 mm
Wheel base	1228 mm
Kerb weight (with toolkit and 90% of fuel)	89 kg (TVS XL100 Heavy Duty i-Touch start) 88 kg (TVS XL100 COMFORT i-TOUCH start / TVS XL 100 HEAVY DUTY / TVS XL 100) 86 kg (TVS XL 100 COMFORT)
Pay load	130 kg
Maximum laden weight	219 kg (TVS XL100 Heavy Duty i-Touch start) 218 kg (TVS XL100 COMFORT i-TOUCH start / TVS XL 100 HEAVY DUTY / TVS XL 100) 216 kg (TVS XL 100 COMFORT)
Frame	Welded tubular step through construction
Front suspension	Telescopic spring type
Rear suspension	Swing arm fitted with hydraulic shock absorbers with variable rated spring

DESCRIPTION	TVS XL100 HEAVY DUTY i-TOUCH start / TVS XL100 COMFORT i-TOUCH start / TVS XL100 HEAVY DUTY / TVS XL100 COMFORT / TVS XL 100
BRAKES	
Front	Hand operated, internally expanding shoe type 110 mm dia.
Rear	Hand operated, internally expanding shoe type 110 mm dia.
TYRE	
Tyre size (Front)	2.50-16 - 6 PR 41L
Tyre size (Rear)	2.50-16 - 6 PR 41L
Tyre pressure (Front)**	1.75 kg/cm ² (25 PSI)
Tyre pressure (Rear - Solo)**	2.46 kg/cm ² (35 PSI)
Tyre pressure (Rear - Dual)**	2.81 kg/cm ² (40 PSI)
ELECTRICAL	
Type	AC generator
Ignition system	Electronic fuel injection with IDI : EMS ECU
Spark plug	BOSCH UR5KC / CHAMPION RG8MC
Spark plug gap	0.6 ± 0.1 mm
Battery type	12V, 3Ah MF battery (ES model) 12V, 2.5Ah Lead Acid battery (KS model)
Body earthing	Negative terminal
Head lamp	12V, 35/35W x 1
DRL	12V, LED

** In cold condition

DESCRIPTION	TVS XL100 HEAVY DUTY i-TOUCH start / TVS XL100 COMFORT i-TOUCH start / TVS XL100 HEAVY DUTY / TVS XL100 COMFORT / TVS XL 100	
ELECTRICAL		
Tail / brake lamp bulb	12V, 5/21W x 1	
Turn signal lamps bulb	12V, 10W x 4	
Speedometer lamp bulb	12V, 3.4W x 1	
Turn signal indicator lamp bulb	12V, 2W x 1	
High beam indicator lamp	12V, 2W x 1	
Low fuel indicator	12V, 2W x 1	
ESIL lamp*	12V, 2W x 1	
Malfunction indicator lamp	12V, 2W x 1	
Horn	12V, DC x 1	
Fuse	12V, 15A x 1 (blade type) (ES model) 12V, 10A x 1 (blade type) (ES model) 12V, 10A x 1 (glass fuse) (ES model)	12V, 15A x 1 (blade type) (KS model) 12V, 7.5A x 1 (blade type) (KS model) 12V, 7.5A x 1 (glass fuse) (KS model)

 **Caution**

Using the bulb other than the specified rating can result in overloading of the electrical system or premature failure of the bulb.

LEDs should not be directly connected with the batteries.

* Applicable for 'i-Touch Start' models only

DESCRIPTION	TVS XL100 HEAVY DUTY i-TOUCH start / TVS XL100 COMFORT i-TOUCH start / TVS XL100 HEAVY DUTY / TVS XL100 COMFORT / TVS XL 100
CAPACITIES	
Fuel	BS VI petrol with minimum RON 91 (Containing upto 10% of ethnlol by volume)
Fuel tank capacity**	4 litres
Engine cum transmission oil grade	TVS TRU4 PREMIUM oil (SAE 10W30 API-SL, JASO MA2)
Engine cum transmission oil capacity	900 ml
Front fork oil grade	20W40 oil / ETL 1F*
Front fork oil capacity	100 ml per leg / 210 ml per leg*

i Note

Specifications are subject to change without notice.

** The fuel tank is not a measuring instrument and the capacity of the fuel tank may vary from the indicated capacity

* Applicable for 'XL100 comfort' models only

GENERAL INFORMATION



Dear Customer,





It is mandatory under the Motor Vehicles Act to insure all motor vehicles. No motor vehicle can be used in a public place without a valid policy of insurance issued by an authorised insurer. Driving a motor vehicle without any such insurance is an offense under Motor Vehicles Act.

To assist our Customers on their insurance requirements such as the prompt issue and renewal of policies as well as expeditious settlement of claims if any, our preferred insurers are:







Follow us on  @tvsvxl  @tvsvlofficial  @tvsvlofficial  TVS XL

TVS MOTOR COMPANY LIMITED, P.B. No.4, Harita, Hosur - 635 109, Tamil Nadu. Tel: +91 (04344) 276780. Fax: +91 (04344) 276878. www.tvsmotor.com

* TVS XL100 was recognised by the prestigious 'India Design Mark' award in 2017.